

Sinotruk International

WEBSITE: <https://www.sinotrukinternation.com>

E-MAIL: sinotruk@sinotrukinternation.com

6.01 HOWO前悬架（850车架，10×16板簧，新前轴）/Front suspension

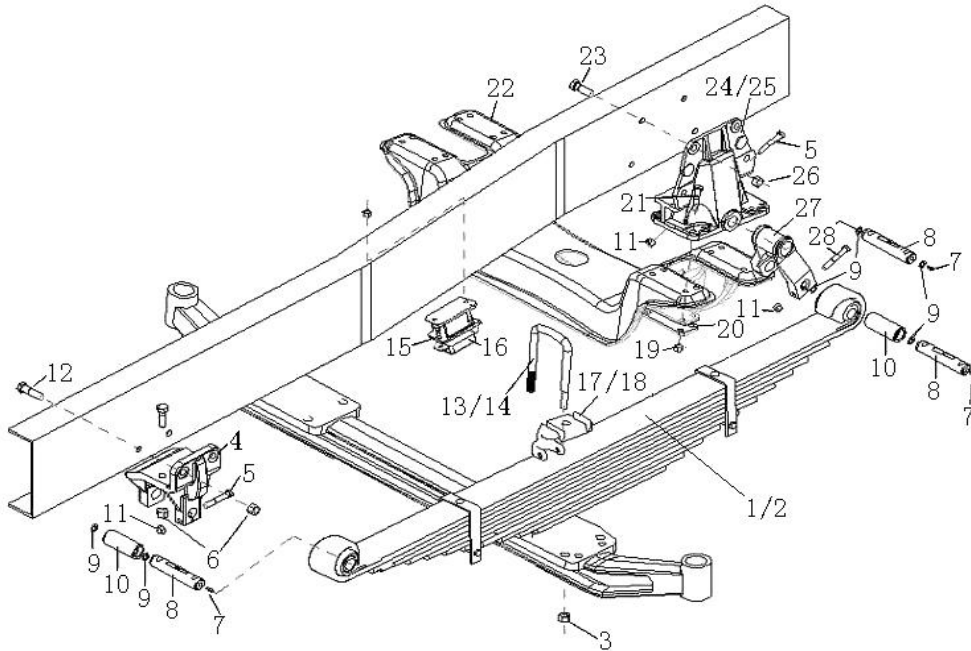

6.01 HOWO前悬架（850车架，10×16板簧，新前轴）/Front suspension

序号 No.	零部件图号 Part No.	名称	Part Name	数量 Qty	备注 Remark
1	WG9725520072	前左钢板弹簧总成（片厚	Front spring ass. -left	1	
1.1	WG9725520072+001	前左钢板弹簧总成（10片	1st piece of front leaf spring	1	
1.2	WG9725520072+002	前左钢板弹簧总成（10片	2nd piece of front leaf spring	1	
1.3	WG9725520072+003	前左钢板弹簧总成（10片	3rd piece of front leaf spring	1	
1.4	WG9725520072+004	前左钢板弹簧总成（10片	4th piece of front leaf spring	1	
1.5	WG9725520072+005	前左钢板弹簧总成（10片	5th piece of front leaf spring	1	
1.6	WG9725520072+006	前左钢板弹簧总成（10片	6th piece of front leaf spring	1	
1.7	WG9725520072+007	前左钢板弹簧总成（片厚	7th piece of front leaf spring	1	
1.8	WG9725520072+008	前左钢板弹簧总成（10片	8th piece of front leaf spring	1	
1.9	WG9725520072+009	前左钢板弹簧总成（10片	9th piece of front leaf spring	1	
1.10	WG9725520072+010	前左钢板弹簧总成（10片	10th piece of front leaf spring	1	
1.11	WG9725520072+012	中心螺栓（10片，片厚16	Central screw	1	
1.12	WG9725520072+013	中心螺母（10片，片厚16	Central nut	1	
2	WG9725520073	前右钢板弹簧总成（片厚	Front spring ass. -right	1	
2.1	WG9725520073+001	前右钢板弹簧总成（10片	1st piece of front right spring	1	
2.2	WG9725520073+002	前右钢板弹簧总成（10片	2nd piece of front right spring	1	
2.3	WG9725520073+003	前右钢板弹簧总成（10片	3rd piece of front right spring	1	

2.4	WG9725520073+004	前右钢板弹簧总成（10片	4th piece of front right sprin	1	
2.5	WG9725520073+005	前右钢板弹簧总成（10片	5th piece of front right sprin	1	
2.6	WG9725520073+006	前右钢板弹簧总成（10片	6th piece of front right sprin	1	

6.01 HOWO前悬架（850车架，10×16板簧，新前轴）/Front suspension

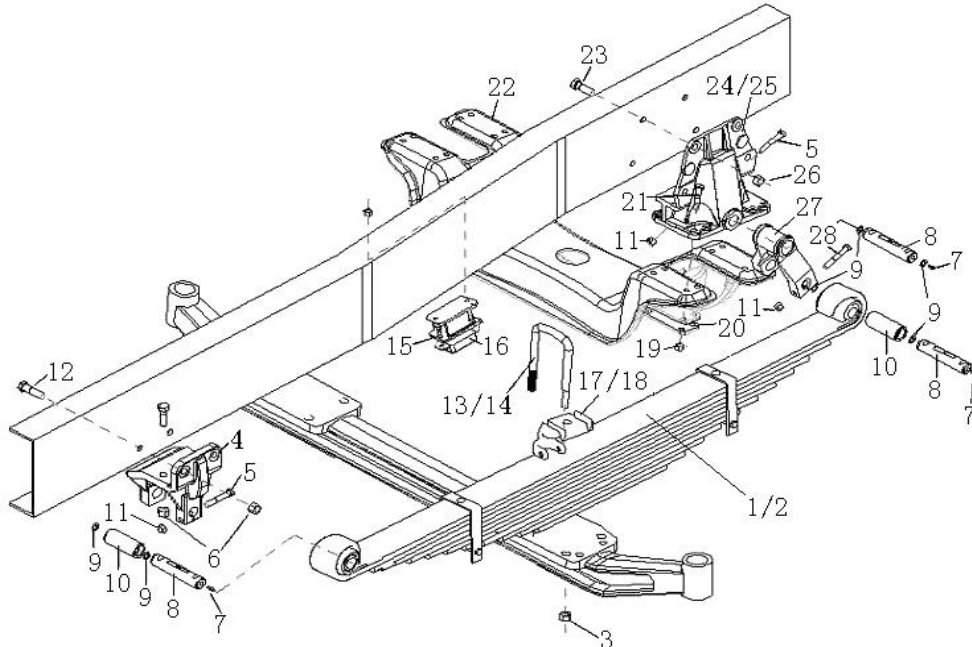

6.01 HOWO前悬架（850车架，10×16板簧，新前轴）/Front suspension

序号	零部件图号	名称	Part Name	数量	备注
No.	Part No.			Qty	Remark
2.7	WG9725520073+007	前右钢板弹簧总成（片厚	7th piece of front right sprin	1	
2.8	WG9725520073+008	前右钢板弹簧总成（10片	8th piece of front right sprin	1	
2.9	WG9725520073+009	前右钢板弹簧总成（10片	9th piece of front right sprin	1	
2.10	WG9725520073+010	前右钢板弹簧总成（10片	10th piece of front right spr	1	
2.11	WG9725520073+012	中心螺栓（10片，片厚16	Central screw	1	
3	Q33020T13F2	全金属六角法兰面锁紧螺	Nut	8	
4	AZ9725520007	前簧前支架	Bracket	2	
5	Q151C1275	六角头螺栓	Bolt	4	
6	190003888459	自锁螺母	Nut	8	
7	AZ9003963022	滑脂嘴总成（CM10*1 D71	Grease nipple	6	
8	WG9100520065	弹簧销	Spring pin	6	
9	1680 520050	垫圈	Washer	12	
10	WG9000520078	衬套	Bushing	4	
11	190003888457	自锁螺母	Nut	6	
12	Q151B1660	六角头螺栓	Bolt	8	
13	AZ9925520230	前簧骑马螺栓	U-bolt	2	
14	AZ9925520029	前簧骑马螺栓	U-bolt	2	

15	WG9731520034	限位支架总成	Bracket assembly	2	
16	WG9416520030	限位块总成	Block assembly	2	
17	WG9925520037	左前簧压板	Plate	1	

6.01 HOWO前悬架（850车架，10×16板簧，新前轴）/Front suspension

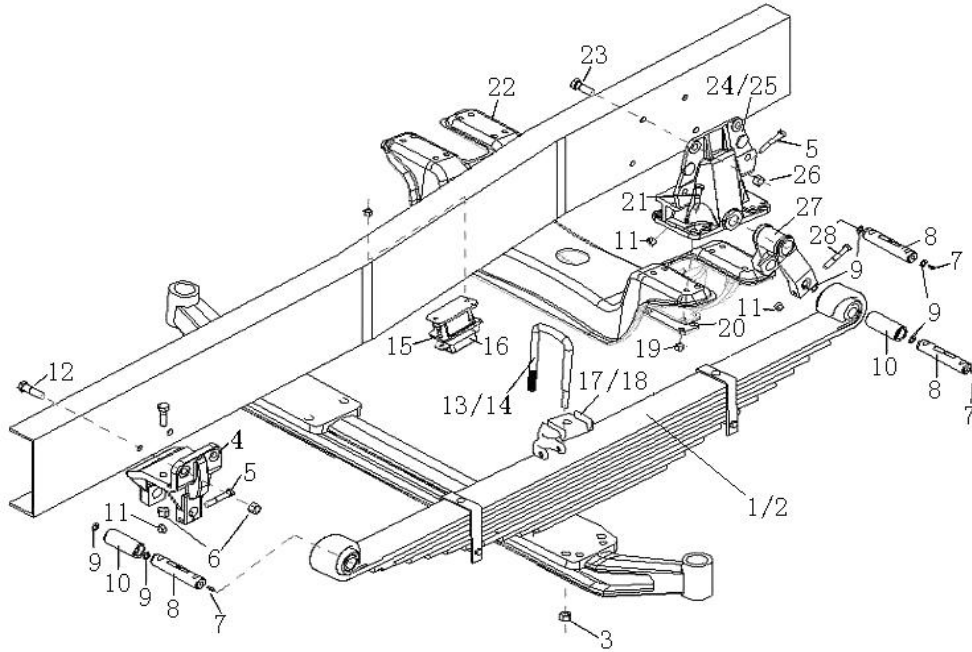

6.01 HOWO前悬架（850车架，10×16板簧，新前轴）/Front suspension

序号	零部件图号	名称	Part Name	数量	备注
No.	Part No.			Qty	Remark
18	WG9925520038	右前簧压板	Plate	1	
19	190003888457	自锁螺母	Nut	16	
20	199100520025	板	Plate	8	
21	Q151C1260	六角头螺栓	Bolt	16	
22	AZ9114510511	横梁总成（加强型）	Cross member	1	
23	Q151B1650	六角头螺栓	Bolt	7	
24	WG9232520010	前簧左后支架	Bracket	1	
25	WG9232520011	前簧右后支架	bracket	1	
26	190003888459	自锁螺母	Nut	7	
27	WG9100520034	前簧吊耳总成	Hanger assembly	2	
28	Q151C1270	六角头螺栓	Bolt	2	
29	Q150B1240	六角头螺栓	Bolt	4	
30	Q150B1230	六角头螺栓	Bolt	4	
31	Q33212	2型全金属六角锁紧螺母	Nut	8	

6.02 HOWO前减震器 (6x4自卸车) /Front Shock Absorber

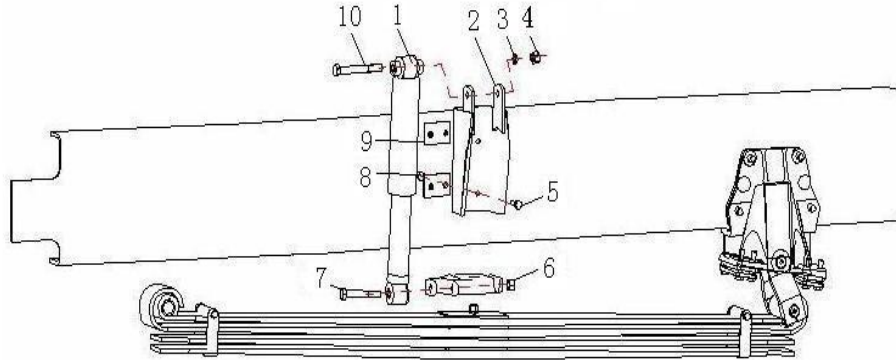

6.02 HOWO前减震器 (6x4自卸车) /Front Shock Absorber

序号	零部件图号	名称	Part Name	数量	备注
No.	Part No.			Qty	Remark
1	WG9925680028	前减振器	Shock Absorber	2	
2	WG9925680026	减震器上支架总成	Bracket assembly	2	
3	Q40016	小垫圈	Washer	2	
4	190003888459	自锁螺母	Nut	2	
5	Q151C1235	六角头螺栓(细牙)	Bolt	8	
6	190003888459	自锁螺母	Nut	2	
7	Q151B16100	六角头螺栓	Bolt	2	
8	190003888457	自锁螺母	Nut	8	
9	WG9100680021	垫板	Plate	4	
10	199100680036	螺栓	Bolt	2	

6.03 9吨前桥横向稳定器/Front Stabilizer

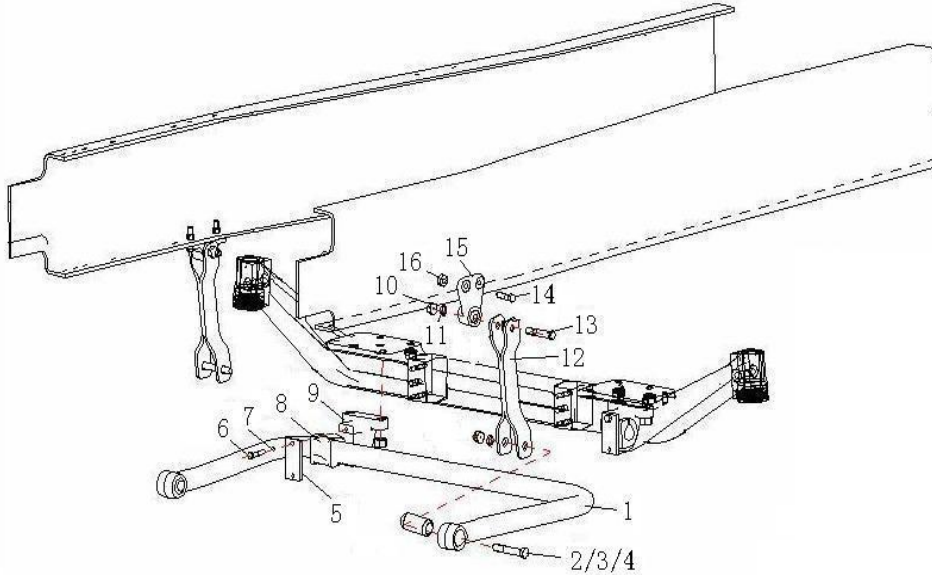

6.03 9吨前桥横向稳定器/Front Stabilizer

序号	零部件图号	名称	Part Name	数量	备注
No.	Part No.			Qty	Remark
1	WG9925680004	前稳定杆总成	Stabilizer bar assembly	1	
2	199100680069	螺栓	Bolt	2	
3	Q40214	大垫圈	Washer	2	
4	190003888458	自锁螺母	Nut	2	
5	WG9925680012	垫板	Plate	2	
6	Q150B1030TF3	六角头螺栓	Bolt	4	
7	Q40310	弹簧垫圈	Spring washer	4	
8	WG9100680068	橡胶轴承	Rubber bearing	2	
9	WG9925680011	固定夹块	Block	2	
10	190003888459	自锁螺母	Nut	2	
11	Q40016	小垫圈	Washer	2	
12	WG9160680055	吊板总成	Plate assembly	2	
13	WG9100680057	螺栓	Bolt	2	
14	Q151C1240	六角头螺栓	Bolt	4	
15	AZ9719680013	稳定杆支架总成	Bracket assembly	2	
16	190003888457	自锁螺母	Nut	4	

6.04 A7后悬架(850、8+8、300高车架、铸造桥、铸造横梁)/Rear suspension

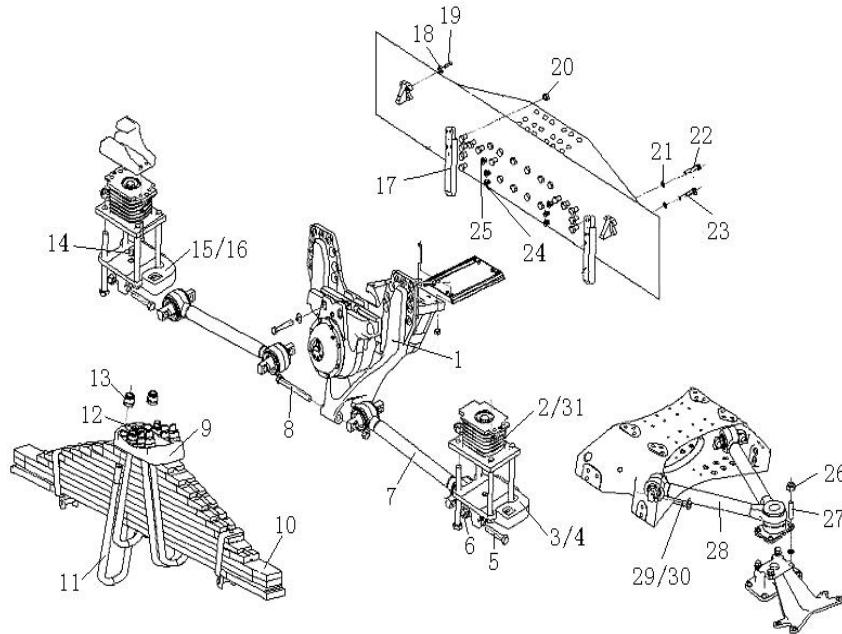

6.04 A7后悬架(850、8+8、300高车架、铸造桥、铸造横梁)/Rear suspension

序号	零部件图号	名称	Part Name	数量	备注
No.	Part No.			Qty	Remark
1	AZ9925520310	平衡轴带轴壳总成	Balance shaft assembly	2	
1.1	AZ9925520233	支架	Bracket	1	
1.10	Q150B0820	六角头螺栓	Bolt	8	
1.11	Q40308	弹簧垫圈	Spring washer	8	
1.12	Q5211630	园柱销	Pin	1	
1.13	WG9014520192	定位垫圈	Washer	1	
1.14	WG9014520193	定位垫圈	Washer	1	
1.15	WG9014520194	定位垫圈	Washer	1	
1.16	WG9014520303	定位垫圈	Washer	1	
1.17	WG9114520059	定位垫圈	Washer	1	
1.18	WG9014520311	壳盖	Cover	1	
1.19	WG9925520235	平衡轴壳	Housing	1	
1.2	AZ9725520237	平衡轴	Balance shaft	1	
1.20	WG9725520136	轴承油封盖	Cover	1	
1.21	WG9925520223	轴密封圈	Gasket	1	
1.22	WG9114520223	轴密封圈	Gasket	1	
1.23	WG9725520238	间隔衬套	Bushing	1	

1.24	WG9014520306	定位垫圈	Washer	1	
1.25	WG9100520008	定位垫圈	Washer	1	
1.26	WG9725520239	轴承压块	Block	1	

6.04 A7后悬架(850、8+8、300高车架、铸造桥、铸造横梁)/Rear suspension

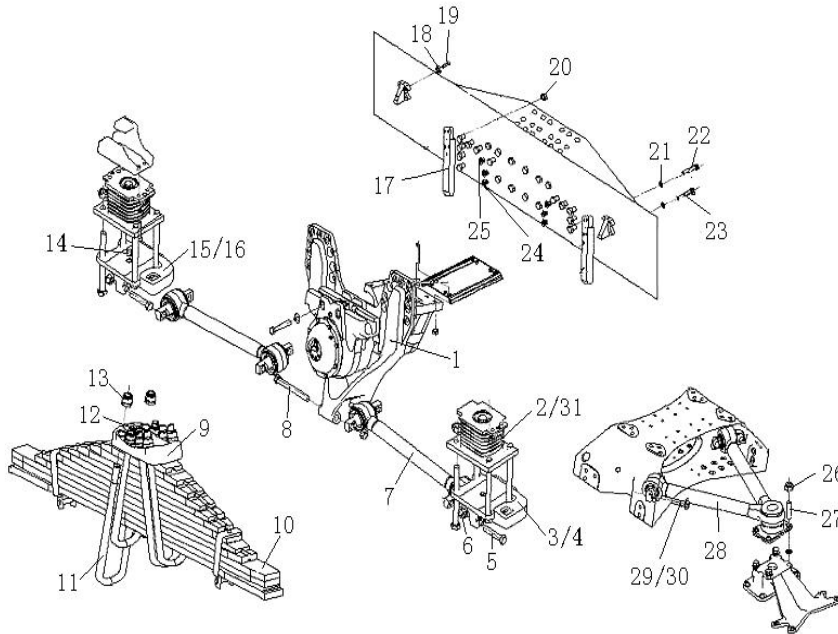

6.04 A7后悬架(850、8+8、300高车架、铸造桥、铸造横梁)/Rear suspension

序号	零部件图号	名称	Part Name	数量	备注
No.	Part No.			Qty	Remark
1.3	WG9114520042	球面轴承	Bearing	2	
1.4	WG614 130062	密封圈	Gasket	1	
1.5	Q150B0810	六角头螺栓	Bolt	1	
1.6	Q72308T5F	密封垫圈	Gasket	1	
1.7	Q150B1445TF2	六角头螺栓	Bolt	6	
1.8	Q40314	弹簧垫圈	Spring washer	6	
1.9	190003962021	锥螺纹内六角螺塞	Plug	1	
2	AZ9925523277	左前橡胶支座总成	left-front rubber bracket as	2	
3	WG9725520194	推力杆后左支架	Bracket	1	
4	WG9725520195	推力杆后右支架	Bracket	1	
5	ZQ151B20100TF6	六角头螺栓M20*1.5	Hexagon head bolts	8	
6	ZQ32320T13F6	六角法兰面螺母M20*1.5	Hexagon nuts with flange	12	
7	AZ9631523175	浇铸式推力杆总成	Rod assembly	4	
7.1	AZ9631521177	球面销总成	Pin assembly	2	
7.2	WG9631520044	直球座	Base	2	
7.3	WG9631520034	挡圈(商用车)	Circlip	2	
7.4	AZ9631521179	垫圈	Washer	2	

7.5	AZ9114521186	连接杆	Rod	1	
8	ZQ18520180TF6	六角法兰面螺栓M20*1.5	Hexagon bolts with flange	4	
9	WG9925520366	板簧压块	Block	2	

6.04 A7后悬架(850、8+8、300高车架、铸造桥、铸造横梁)/Rear suspension

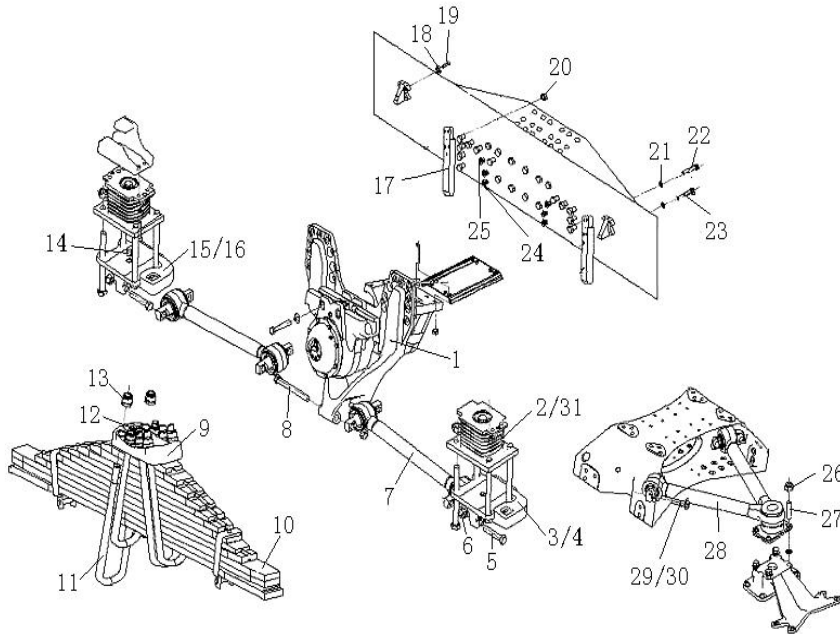

6.04 A7后悬架(850、8+8、300高车架、铸造桥、铸造横梁)/Rear suspension

序号	零部件图号	名称	Part Name	数量	备注
No.	Part No.			Qty	Remark
10	WG9725520286	后钢板弹簧总成	Rear leaf spring	2	
10.1	WG9725520286+001	后钢板弹簧总成(张弹)第	1st piece of rear spring	1	
10.2	WG9725520286+002	后钢板弹簧总成(张弹)第	2nd piece of rear spring	1	
10.3	WG9725520286+003	后钢板弹簧总成(张弹)第	3rd piece of rear spring	1	
10.4	WG9725520286+004	后钢板弹簧总成(张弹)第	4th piece of rear spring	1	
10.5	WG9725520286+005	后钢板弹簧总成(张弹)第	5th piece of rear spring	1	
10.6	WG9725520286+006	后钢板弹簧总成(张弹)第	6th piece of rear spring	1	
10.7	WG9725520286+007	后钢板弹簧总成(张弹)第	7th piece of rear spring	1	
10.8	WG9725520286+008	后钢板弹簧总成(张弹)第	8th piece of rear spring	1	
10.9	WG9725520286+009	后钢板弹簧总成(张弹)第	9th piece of rear spring	1	
10.10	WG9725520286+010	后钢板弹簧总成(张弹)第	10th piece of rear spring	1	
10.11	WG9725520286+011	后钢板弹簧总成(张弹)第	11th piece of rear spring	1	
10.12	WG9725520286+012	后钢板弹簧总成(张弹)第	12th piece of rear spring	1	
10.13	WG9725520286+013	中心螺栓	Central screw	1	
10.14	WG9725520286+014	中心螺母	Central nut	1	
11	AZ9925520268	后簧骑马螺栓	U-bolt	8	
12	WG9000520006	导向销	Pin	4	

13	ZQ32724T13F3	凸缘螺母M24*3	Nut	16	
14	190003901905	园柱销一销GB119 A20*24	Pin	4	
15	WG9725520290	推力杆前左支架 (HW1279材	Bracket	1	

6.04 A7后悬架(850、8+8、300高车架、铸造桥、铸造横梁)/Rear suspension

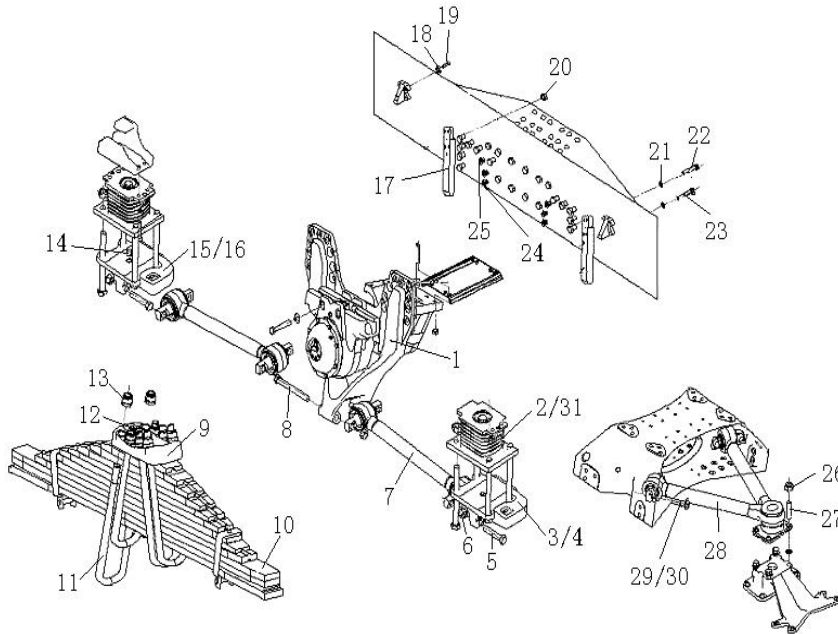

6.04 A7后悬架(850、8+8、300高车架、铸造桥、铸造横梁)/Rear suspension

序号	零部件图号	名称	Part Name	数量	备注
No.	Part No.			Qty	Remark
16	WG9725520291	推力杆前右支架 (HW1279材	Bracket	1	
17	WG9725520250	导向板	Guide plate	4	
18	Q40310	弹簧垫圈	Spring washer	16	
19	ZQ151B1470	六角头螺栓M14*1.5	Hexagon head bolts	12	
20	ZQ361B14	2型六角螺母M14*1.5	Hexagon nuts ,style 2	16	
21	Q40312	弹簧垫圈	Spring washer	16	
22	Q151C1260	六角头螺栓	Bolt	16	
23	ZQ151B1460	六角头螺栓M14*1.5	Hexagon head bolts	4	
24	WG9925521014	内六角沉头螺钉	Hexagon Socket Countersun	8	
25	WG9925521007	内六角沉头螺钉	Hexagon Socket Countersun	4	
26	ZQ32318T13F6	六角法兰面螺母M18*1.5	Hexagon nuts with flange	8	
27	WG9725520227	双头螺栓	Stud	8	
28	AZ9725529272	V型推力杆总成	Rod assembly	2	
28.10	AZ9725527211	连接杆	Rod	2	
28.1	WG9725527202	推力杆安装座	pushing rod braket	1	
28.11	WG9725529213	球面销总成	Pin assembly	2	
28.12	AZ9725529216	锁圈	Circlip	4	

28.13	WG9725526201	上球座	Base	1	
28.14	WG9725527203	卡簧	Clip	1	
28.15	WG9725528212	直球座	Base	2	

6.04 A7后悬架(850、8+8、300高车架、铸造桥、铸造横梁)/Rear suspension

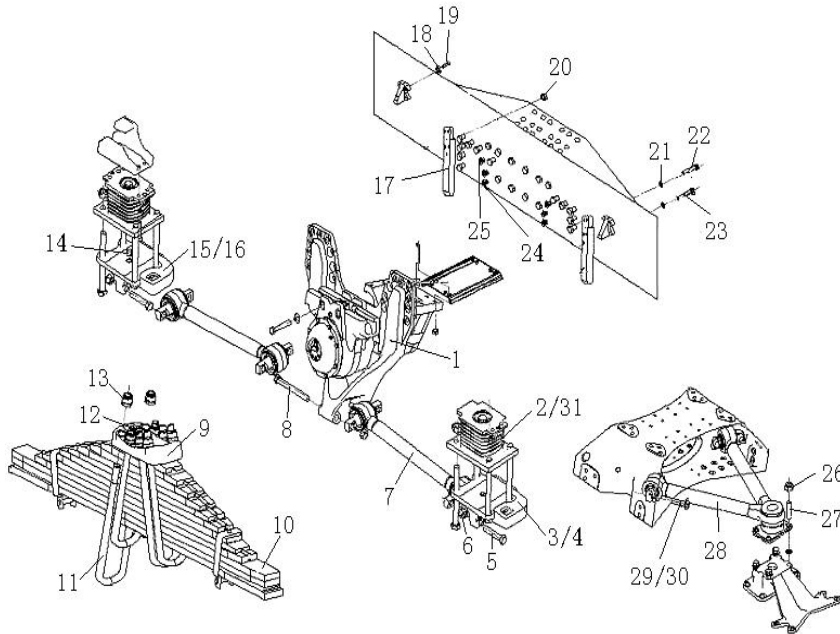

6.04 A7后悬架(850、8+8、300高车架、铸造桥、铸造横梁)/Rear suspension

序号	零部件图号	名称	Part Name	数量	备注
No.	Part No.			Qty	Remark
28.16	WG9725529209	直球座挡圈	Circlip	2	
28.17	WG9725529214	内密封圈	Gasket	2	
28.18	WG9725529215	外密封圈	Gasket	2	
28.2	WG9725527204	护套	bush	1	
28.3	WG9725527215	喉箍总成	Clamp assembly	1	
28.4	WG9725526205	关节轴承总成	Bearing assembly	1	
28.5	Q151B1855TF2	六角头螺栓	Bolt	1	
28.6	Q40118	平垫圈	Washer	1	
28.7	Q40518	弹簧垫圈	Spring washer	1	
28.8	WG9725527209	上球座挡圈	Bracket washer	1	
28.9	WG9725527210	上端盖	top casing	1	
29	WG9725520367	防松套	Sleeve	8	
30	WG9725520114	V型推力杆螺栓	Bolt of V rod	8	
31	AZ9925523279	右前橡胶支座总成	right-front rubber bracket	2	
32	ZQ361B16T13F6	2型六角螺母M16*1.5	Hexagon nuts ,style 2	4	
33	ZQ32516T13F6	六角法兰面带齿螺母M16*	Hexagon flange nuts with te	34	
34	ZQ151B22235TF6	六角头螺栓M22*1.5	Hexagon head bolts	16	

6.05 后横向稳定器/Stabilizer assembly

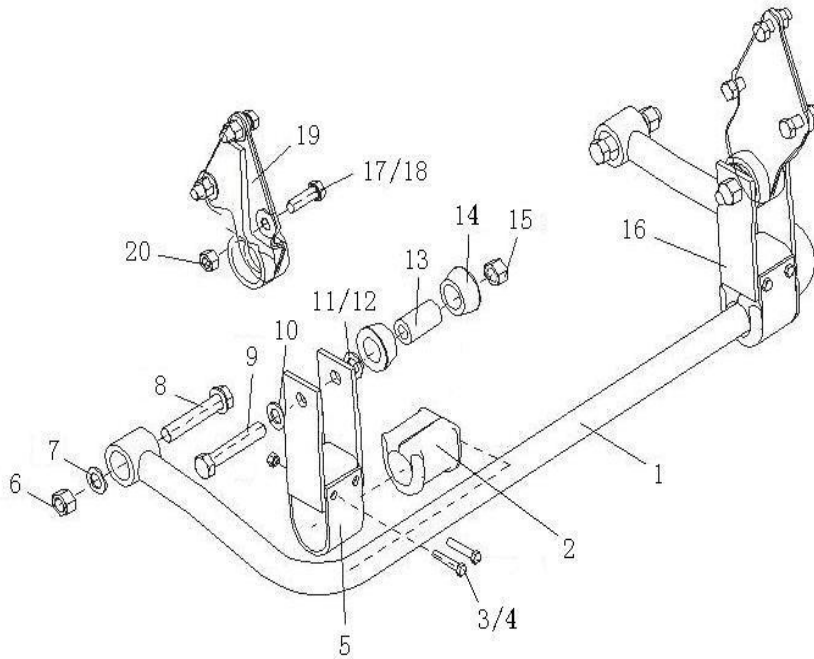

6.05 后横向稳定器/Stabilizer assembly

序号	零部件图号	名称	Part Name	数量	备注
No.	Part No.			Qty	Remark
1	WG9719680006	后稳定杆总成	Stabilizer bar assembly	1	
2	WG9100680067	橡胶轴承	Rubber bearing	2	
3	Q151C12100	六角头螺栓	Bolt	4	
4	190003888457	自锁螺母	Nut	4	
5	WG780 680032	轴承夹	Bearing clip	2	
6	190003888459	自锁螺母	Nut	2	
7	1780 680030	垫圈	Washer	2	
8	WG80 680029	螺栓	Bolt	2	
9	WG80 680029	螺栓	Bolt	2	
10	WG9100680071	垫圈	Washer	2	
11	190003930010	垫圈	Washer	2	
12	1780 680030	垫圈	Washer	2	
13	199100680037	套筒	Sleeve	2	
14	199100680066	轴承	Bearing	4	
15	190003888459	自锁螺母	Nut	2	
16	WG9719680061	平衡夹总成	Circlip assembly	2	
17	Q151B1650	六角头螺栓	Bolt	4	

18	Q151B1655	六角头螺栓	Bolt	2	
19	199100510008	稳定杆托架	Bracket	2	
20	190003888459	自锁螺母	Nut	6	