

Sinotruk International

WEBSITE: <https://www.sinotrukinternational.com>

E-MAIL: sinotruk@sinotrukinternational.com

7.01 过电压报警装置/Over Voltage Alarming Device

Wireless terminal (x20) for 30 point power

30点电源接线端X20

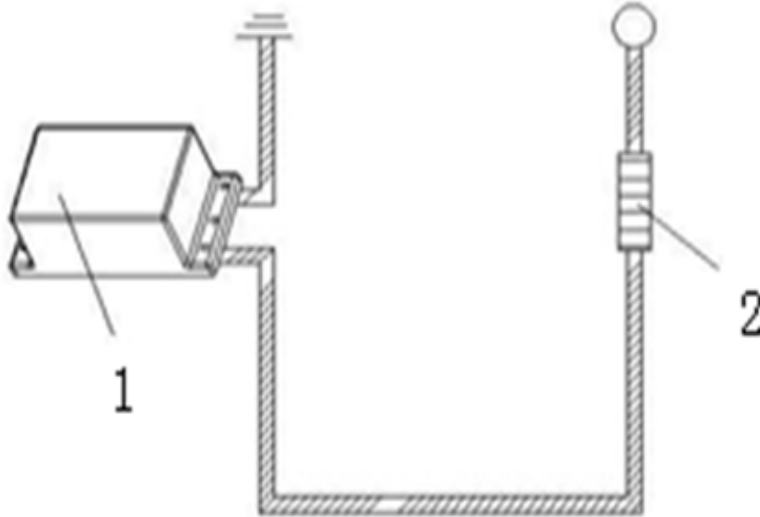

7.01 过电压报警装置/Over Voltage Alarming Device

序号	零部件图号	名称	Part Name	数量	备注
No.	Part No.			Qty	Remark
1	WG1500090201	过电压报警装置	Over voltage alarming device	1	
1a	AZ1664930001	塑料螺母座	Nut seat	4	
1b	Q2204816F31	组合件	Combination screw	4	
2	WG9725580009	5A保险装置	5A Fuse box	1	
	WG9725580011	底座	Base	1	

7.02 09款电气控制系统(VDO)/Electric Control System(VDO)

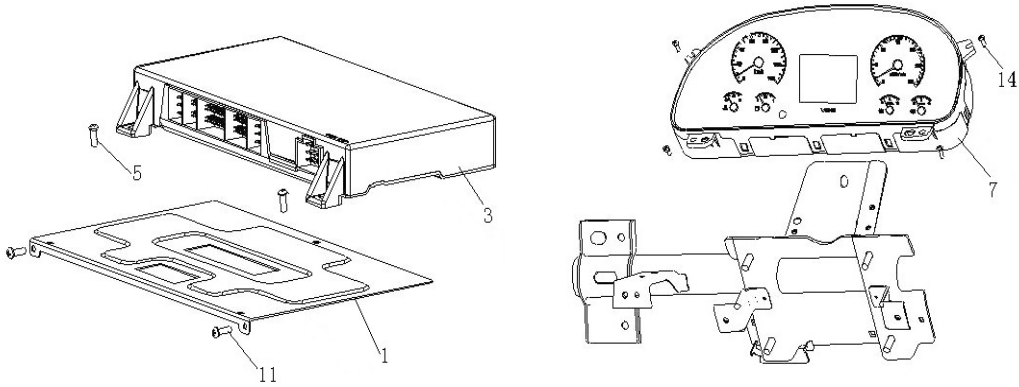

7.02 09款电气控制系统(VDO)/Electric Control System(VDO)

序号	零部件图号	名称	Part Name	数量	备注
No.	Part No.			Qty	Remark
1	AZ9724580002	CBCU安装板	CBCU Plate	1	
2	Q2714216	十字槽盘头自攻螺钉	Screw	2	
3	WG9716580023	中央控制单元 (CBCU)	CBCU	1	
5	Q2140512	十字槽盘头螺钉	Screw	3	
6	Q40105	平垫圈	Washer	3	
7	WG9716580025	组合仪表 (CMIC)	CMIC	1	
9	Q2714816	十字槽盘头自攻螺钉	Screw	4	
10	Q40105	平垫圈	Washer	4	
11	Q2714216F31	十字槽盘头自攻螺钉	Screw	2	
12	Q340B05	1型六角螺母	Nut	3	
13	Q340B05	1型六角螺母	Nut	3	
14	Q2714816F31	十字槽盘头自攻螺钉	Screw	4	

7.03 电器装置/Electric Equipment

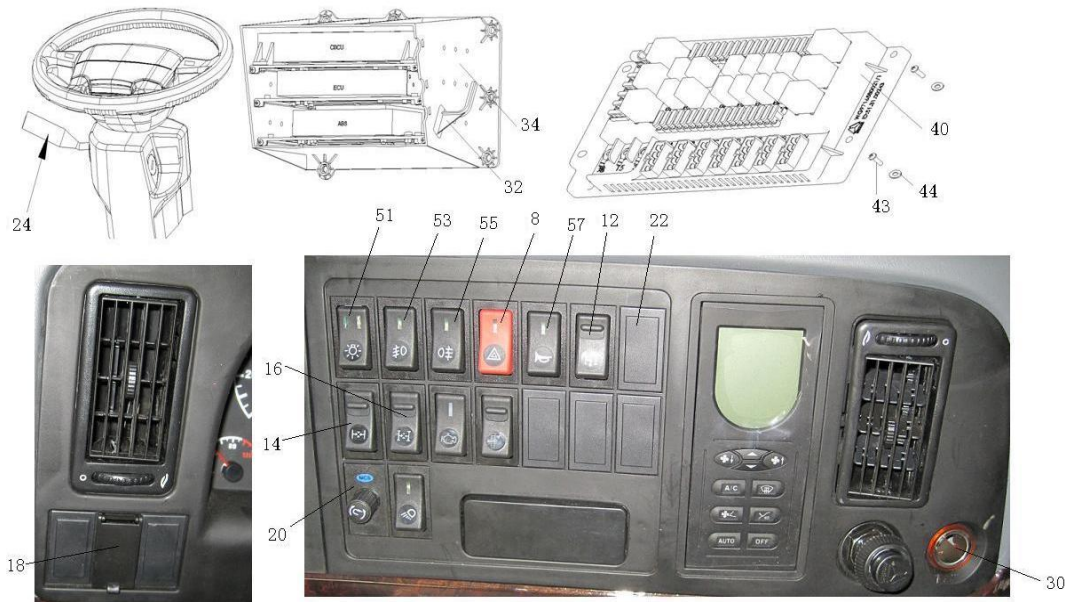

7.03 电器装置/Electric Equipment

序号 No.	零部件图号 Part No.	名称	Part Name	数量 Qty	备注 Remark
8	WG9719584004	危急报警开关	Emer. alarming switch	1	
12	WG9719582010	取力器开关	PTO switch	1	
14	WG9719582011	轮差开关	Inter wheel diff.lock switch	1	
16	WG9719582012	轴差开关	Inter axle diff.lock switch	1	
18	WG9725580005	诊断接口外壳	Cover for diagnosis joint	1	
20	WG9719582054	MCS旋钮	MCS Knob	1	
22	WG9900580021	盖板	Plate	7	
24	WG9130583117	组合开关(转向柱上)	Combined switch	1	
26	Q2540512	十字槽沉头螺钉	Screw	3	
27	Q40105	平垫圈	Washer	3	
28	Q40305	弹簧垫圈	Spring washer	3	
29	AZ9725580030	橡胶堵盖	Rubber plug	1	
30	WG9100580142	24V点烟器	Cigarette light (24V)	1	
32	WG9725584026	线束固定夹	Wireness clip	1	
34	WG9725584029	ECU安装箱	ECU box	1	
36	Q150B0825	六角头螺栓	Screw	5	

37	Q40108	平垫圈	Washer	5	
38	Q40308	弹簧垫圈	Spring washer	5	
39	Q340B08	1型六角螺母	Nut	5	
40	WG9716580021	电气接线盒总成	Wire connecting box	1	

7.03 电器装置/Electric Equipment

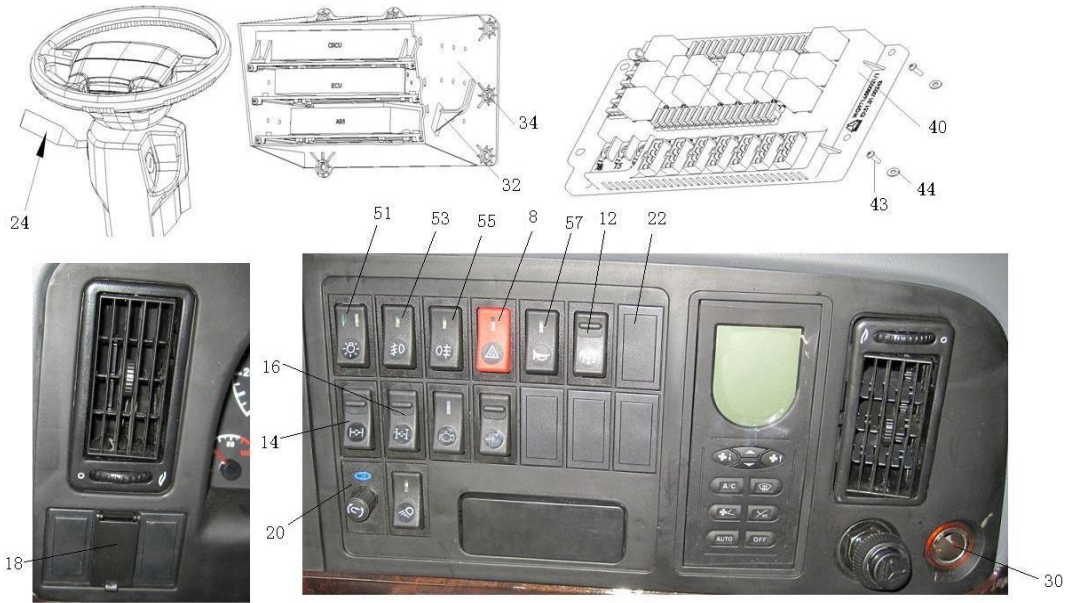

7.03 电器装置/Electric Equipment

序号	零部件图号	名称	Part Name	数量	备注
No.	Part No.			Qty	Remark
43	Q2140635	盘头螺钉	Screw	4	
44	Q40106	平垫圈	Washer	4	
46	WG9725584001	40A常开式继电器	40A Relay (normally on)	3	
48	WG9725584002	20A常开式继电器	20A Relay (normally off)	7	
51	WG9719584011	灯光开关	Light switch	1	
53	WG9719584012	前雾灯开关	Front fog lamp switch	1	
55	WG9719584013	后雾灯开关	Rear fog lamp switch	1	
57	WG9719584015	喇叭开关	Horn switch	1	

7.04 HW电气接线盒铭牌(英文)/Nameplate

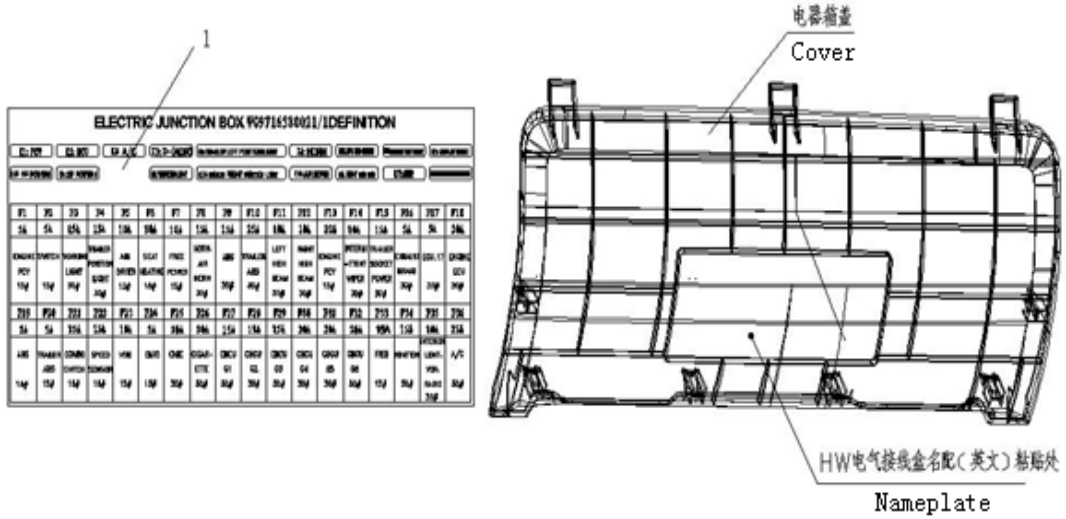

7.04 HW电气接线盒铭牌(英文)/Nameplate

序号	零部件图号	名称	Part Name	数量	备注
No.	Part No.			Qty	Remark
1	AZ9724580005	HW电气接线盒铭牌(英文)	Nameplate	1	

7.05 145-320马力4*2/4*4底盘电器/Chassis Electric Device

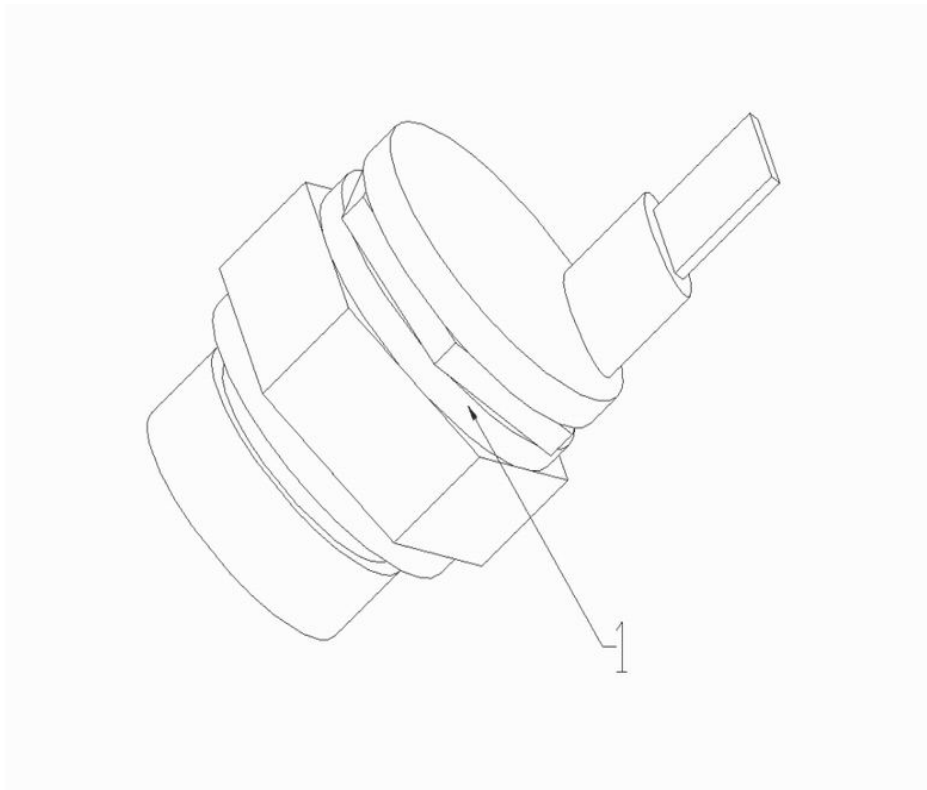

7.05 145-320马力4*2/4*4底盘电器/Chassis Electric Device

序号	零部件图号	名称	Part Name	数量	备注
No.	Part No.			Qty	Remark
1	WG9100710003	压力开关	Pressure switch	1	
3	Q72318T5F	密封垫圈	Sealing	1	

7.06 底盘电器 2/Chassis Electric Device 2

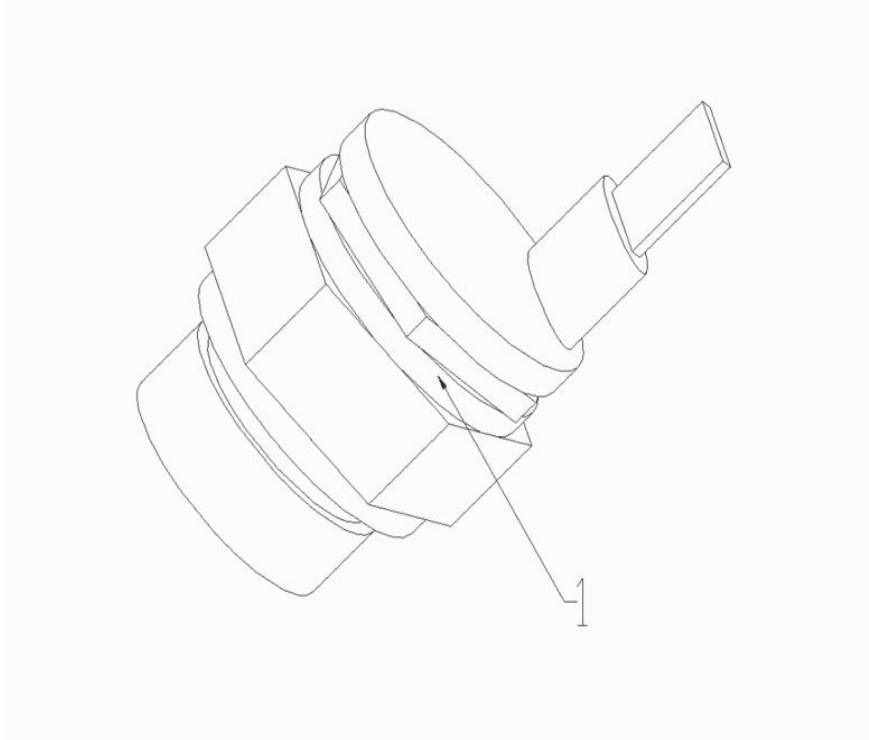

7.06 底盘电器 2/Chassis Electric Device 2

序号	零部件图号	名称	Part Name	数量	备注
No.	Part No.			Qty	Remark
1	WG9100710003	压力开关	Pressure switch	2	
3	Q72318T5F	密封垫圈	Sealing	2	

7.07 底盘电器 3/Chassis Electric Device 3

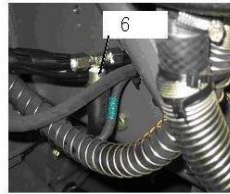
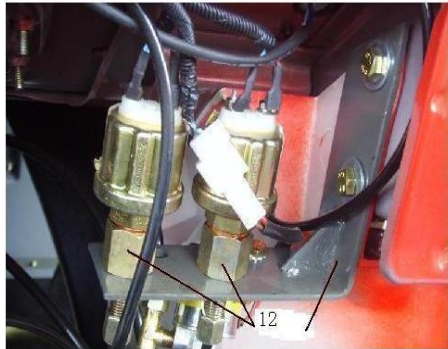
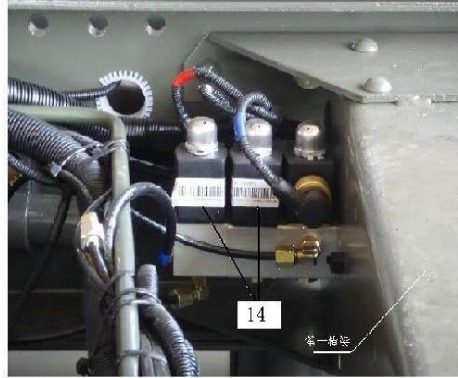

7.07 底盘电器 3/Chassis Electric Device 3

序号 No.	零部件图号 Part No.	名称	Part Name	数量 Qty	备注 Remark
2	WG9718710002	盆形电喇叭	Electric horn	1	
4	Q1460825	组合件	Combination screw	1	
5	Q340B08	1型六角螺母	Nut	1	
6	WG9100710004	气压信号灯开关	Switch - air signal lamp	2	
8	WG9725710004	支架	Bracket	1	
10	Q2140620F31	十字槽盘头螺钉	Screw	2	
11	Q40306	弹簧垫圈	Spring washer	2	
12	WG9727710002	电子式气压传感器	Air pressure sensor	2	
14	WG9719710004	电磁阀(P99接头)	Solenoid valve	4	
16	Q150B0875	六角头螺栓	Screw	2	
17	Q150B08190	六角头螺栓	Screw	2	
18	Q40308	弹簧垫圈	Spring washer	4	
19	Q340B08	1型六角螺母	Nut	4	
20	WG9725584002	20A常开式继电器	20A relay (normally on)	1	
22	Q2140410	十字槽盘头螺钉	Screw	1	
23	Q40304	弹簧垫圈	Spring washer	1	

24	Q40104	平垫圈	Washer	1	
25	WG9725580086	铅封		1	
27	190000810930	铅封线		40	
28	WG9725580006	100A保险装置	100A fuse	1	

7.07 底盘电器 3/Chassis Electric Device 3

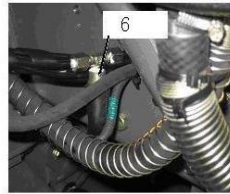
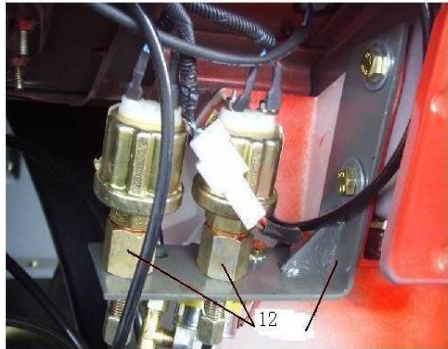
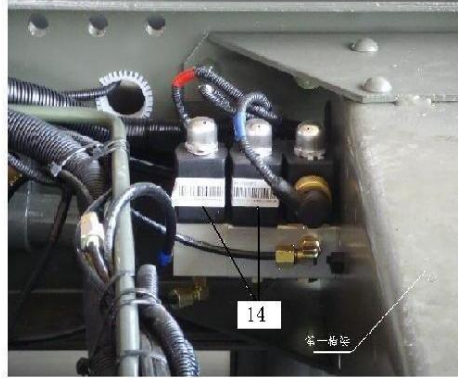

7.07 底盘电器 3/Chassis Electric Device 3

序号	零部件图号	名称	Part Name	数量	备注
No.	Part No.			Qty	Remark
31	Q150B0620	六角头螺栓	Screw	2	
32	Q40306	弹簧垫圈	Spring washer	2	
33	Q40106	平垫圈	Washer	2	
34	Q340B06	I型六角螺母	Nut	2	

7.08 HW7车下起动电器装置（北京奥博）/Under the car start/stop electrical device

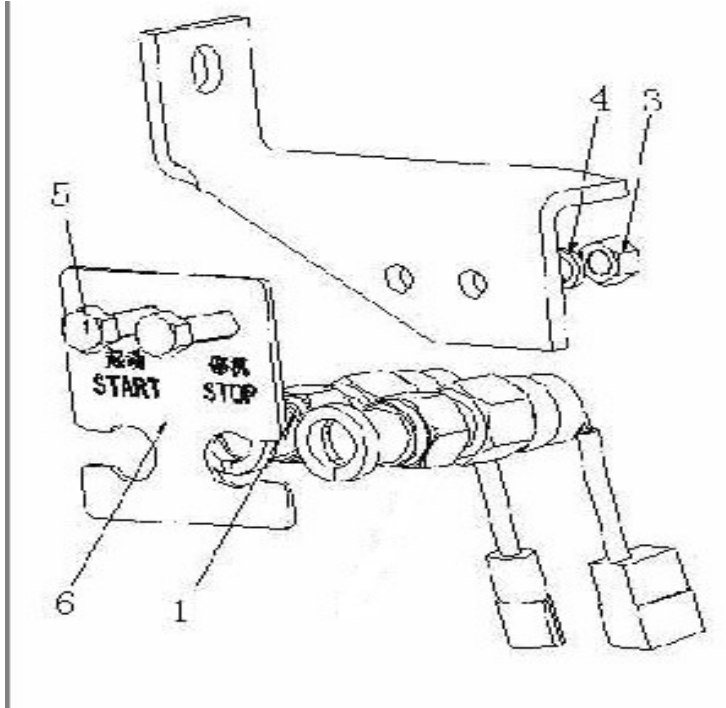

7.08 HW7车下起动电器装置（北京奥博）/Under the car start/stop electrical device

序号 No.	零部件图号 Part No.	名称	Part Name	数量 Qty	备注 Remark
1	WG9918580017	车下起动/停机开关总成	Under the car start/stop swit	1	
3	Q150B0820	六角头螺栓	Bolt	2	
4	Q40308	弹簧垫圈	Spring washer	2	
5	Q340B08	1型六角螺母	Nut	2	
6	AZ9727776023	车下起动/停机电线束（E	Under the car start/stop swit	1	
8	190003171393	塑料紧固带B8*200	Cable binder	10	

7.09 HOWO车前照灯/Headlamp

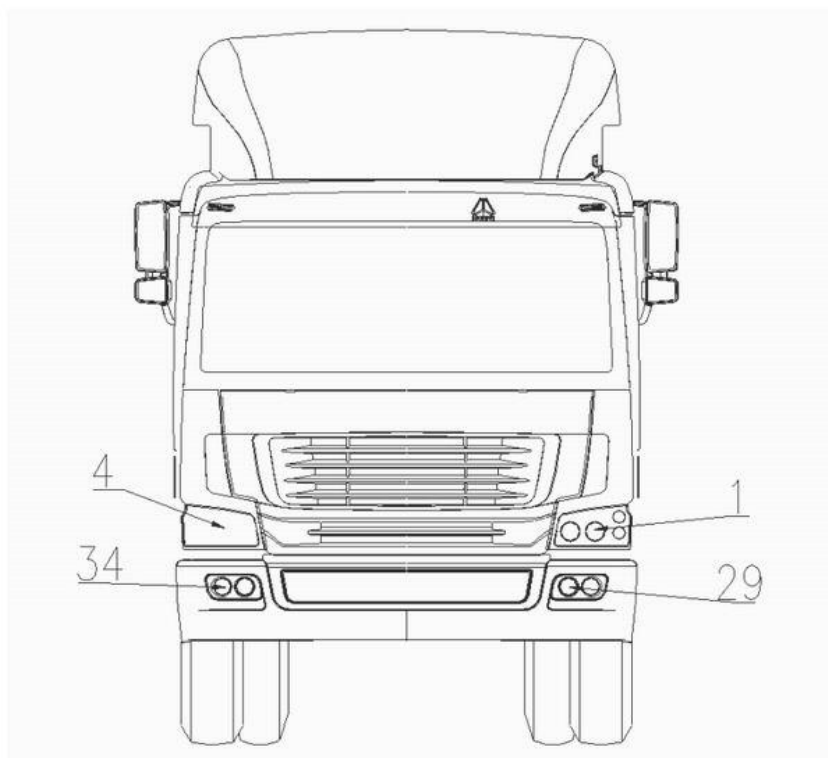

7.09 HOWO车前照灯/Headlamp

序号 No.	零部件图号 Part No.	名称	Part Name	数量 Qty	备注 Remark
1	WG9719720001	左前照灯总成	Headlamp ass. -left	1	
4	WG9719720002	右前照灯总成	Headlamp ass. -right	1	
4a	Q150B0822	六角头螺栓	Screw	2	
4b	Q150B0816	六角头螺栓	Screw	2	
4c	Q340B08	I型六角螺母	Nut	4	
4d	Q40108	平垫圈	Washer	8	
4e	Q40308	弹簧垫圈	Spring washer	4	
4f	Q2140620	十字槽盘头螺钉	Screw	4	
4g	Q40106	平垫圈	Washer	4	
4h	Q40306	弹簧垫圈	Spring washer	4	
6	AZ9718720002	前照灯安装板	Plate	2	
6a	Q150B0820	六角头螺栓	Screw	6	
6b	Q40308	弹簧垫圈	Spring washer	6	
8	AZ9718720003	连接板	Plate	2	
8a	Q150B0616	六角头螺栓	Screw	4	
8b	Q340B06	I型六角螺母	Nut	4	
8c	Q40106	平垫圈	Washer	4	

8d	Q40306	弹簧垫圈	Spring washer	4	
8e	Q40108	平垫圈	Washer	6	
8f	Q40308	弹簧垫圈	Spring washer	6	
8g	Q150B0820	六角头螺栓	Screw	6	

7.09 HOWO车前照灯/Headlamp

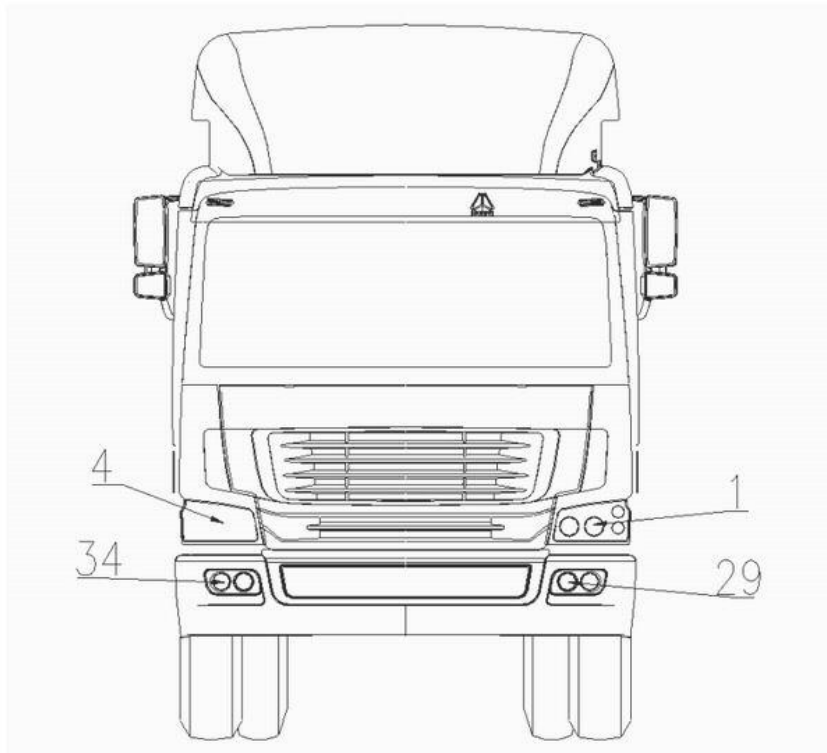

7.09 HOWO车前照灯/Headlamp

序号	零部件图号	名称	Part Name	数量	备注
No.	Part No.			Qty	Remark
29	WG9719720005	左前组合灯总成	Front lamp -left	1	
29a	Q150B0820	六角头螺栓	Screw	4	
29b	Q40308	弹簧垫圈	Spring washer	4	
34	WG9719720006	右前组合灯总成	Front lamp -right	1	
34a	Q150B0820	六角头螺栓	Screw	4	
34b	Q40308	弹簧垫圈	Spring washer	4	
39	Q40208	大垫圈	Washer	6	
40	WG9719720003	雾灯	Foglight	1	

7.10 蓄电池（165安-时）/165 AH Battery



7.10 蓄电池（165安-时）/165 AH Battery

序号 No.	零部件图号 Part No.	名称	Part Name	数量 Qty	备注 Remark
4	WG9100760065	165安-时标准蓄电池	165AH Battery	2	

7.11 新型电瓶箱/Battery Box

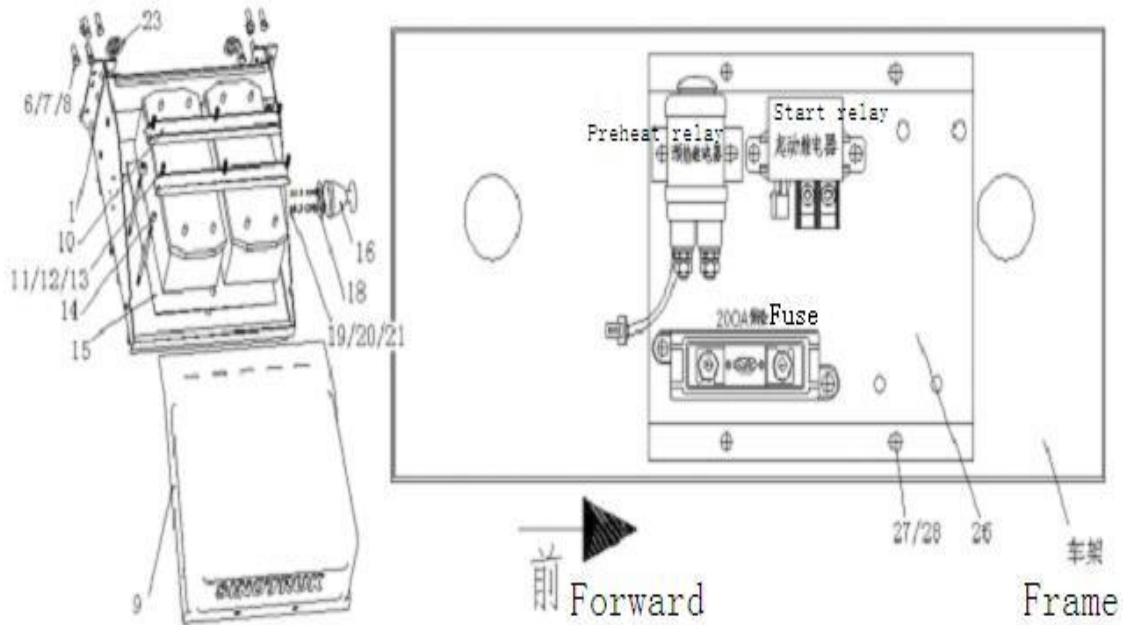

7.11 新型电瓶箱/Battery Box

序号	零部件图号	名称	Part Name	数量	备注
No.	Part No.			Qty	Remark
1	AZ9725760005	HOWO电瓶箱体总成	Battery Box	1	
1.1	AZ9100760110	电瓶箱锁总成	Lock ass.	2	
1.2	AZ9725760003	HOWO电瓶箱体总成	Battery Box	1	
6	Q151B1645	六角头螺栓	Screw	4	
7	Q151B1650	六角头螺栓	Screw	4	
8	190003888459	自锁螺母	Nut	8	
9	AZ9100760102	电瓶箱盖	Battery box cover	1	
10	AZ9100760104	压板	Plate	2	
11	Q340B08	1型六角螺母	Nut	6	
12	Q40208	大垫圈	Washer	6	
13	Q40308	弹簧垫圈	Spring washer	6	
14	1682 110021	橡胶缓冲块	Rubber cussion	6	
15	AZ9100760108	下橡胶垫板	Rubber cussion	1	
16	WG9100760100	电源总开关	Main switch	1	
18	199100760099	密封垫	Gasket	1	
19	Q150B0835	六角头螺栓	Screw	2	
20	Q40308	弹簧垫圈	Spring washer	2	
21	Q40108	平垫圈	Washer	2	
22	Q340B08	1型六角螺母	Nut	2	
23	AZ9719770058	橡胶过孔护圈 (Φ50/Φ3)	Rubber ring	2	

24	Q150B0620	六角头螺栓	Screw	2	
26	AZ9925760004	电器连接板	Plate	1	
27	Q150B0814	六角头螺栓	Screw	4	
28	Q33208	锁紧螺母	Nut	4	

7.12 尾灯电线/Rear Lamp Wireness

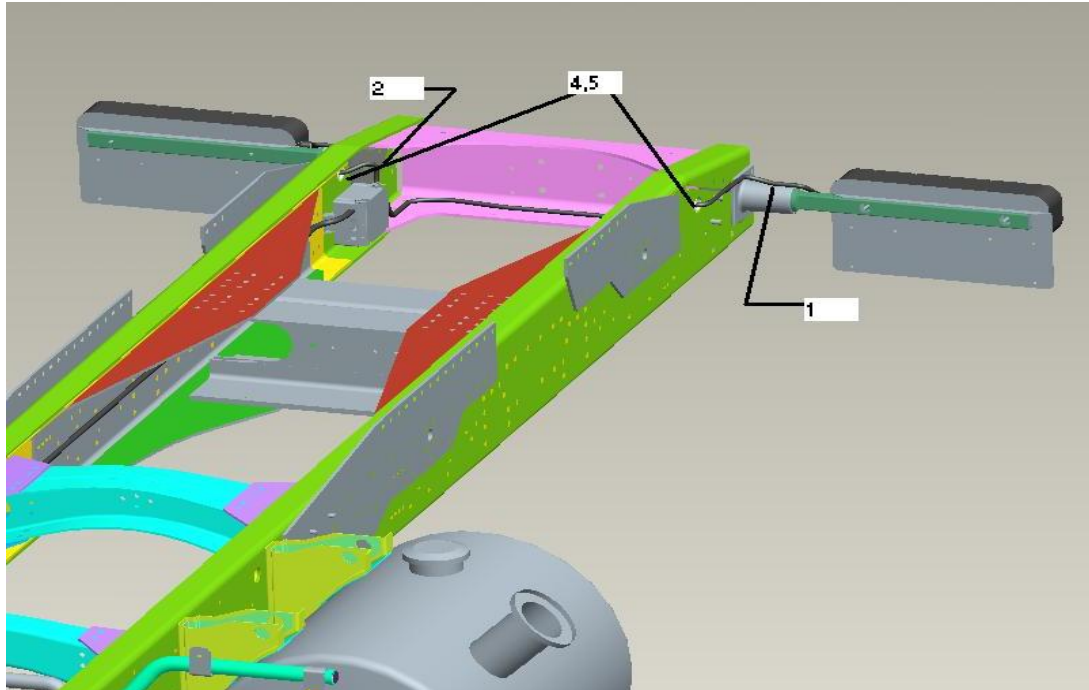

7.12 尾灯电线/Rear Lamp Wireness

序号 No.	零部件图号 Part No.	名称	Part Name	数量 Qty	备注 Remark
1	AZ9725770064	左组合后灯电线束	Rear lamp wireness - left	1	
2	AZ9725770035	右组合后灯电线束	Rear lamp wireness - right	1	
3	190003171393	塑料紧固带B8*200	Fastener	6	
4	190003179045	穿线护套	Protect pipe	125mm	
5	190003179045	穿线护套	Protect pipe	125mm	

7.13 轮、轴间差速锁电线束/Diff. Lock Wireness



7.13 轮、轴间差速锁电线束/Diff. Lock Wireness

序号 No.	零部件图号 Part No.	名称	Part Name	数量 Qty	备注 Remark
1	AZ9725770081	轮、轴差速锁电线束	Diff.Lock Wireness	1	
2	190003171697	塑料紧箍带	Fastener	10	

7.14 车架电线束/Chassis Wireness

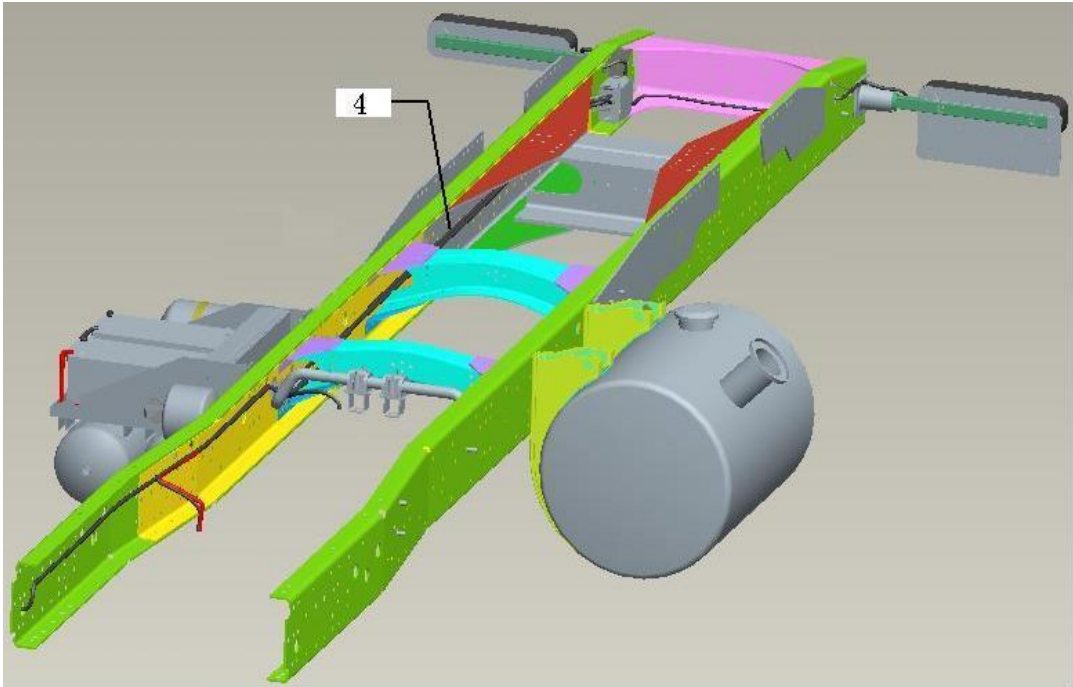

7.14 车架电线束/Chassis Wireness

序号 No.	零部件图号 Part No.	名称	Part Name	数量 Qty	备注 Remark
1	WG9100360134	隔环	Ring	7	
3	190003171393	塑料紧固带B8*200	Fastener	7	
4	AZ9725776033	车架电线束	Wireness	1	
5	WG97 350169	角形支架	Angle	1	
7	Q40112	平垫圈	Washer	1	

7.15 起动机负极至后分线盒搭铁线/Wireness

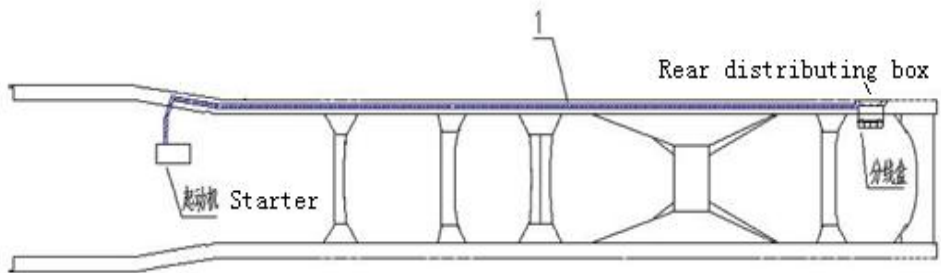

7.15 起动机负极至后分线盒搭铁线/Wireness

序号	零部件图号	名称	Part Name	数量	备注
No.	Part No.			Qty	Remark
1	AZ9725770074	起动机负极至后分线盒搭铁线	Wireness- starter to distributing box	1	

7.16 国2车型启动附加电线束/Starter wiring harness

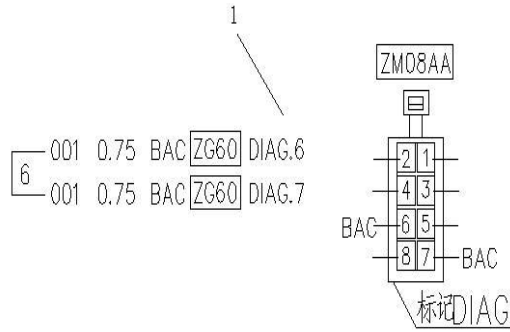

7.16 国2车型启动附加电线束/Starter wiring harness

序号	零部件图号	名称	Part Name	数量	备注
No.	Part No.			Qty	Remark
1	AZ9727770023	启动附加电线束	Starter wiring harness	1	

7.17 起动机电线束/Starter Wireness

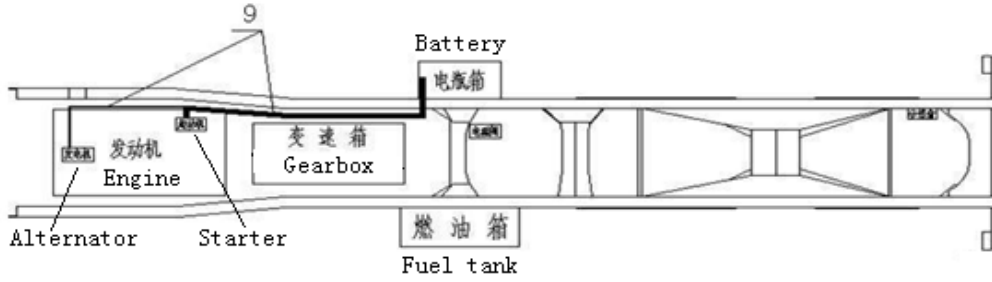

7.17 起动机电线束/Starter Wireness

序号 No.	零部件图号 Part No.	名称	Part Name	数量 Qty	备注 Remark
9	AZ9721778202	起动机电线束(1520)	Wireness - battery to starter	1	
9a	WG9100360134	隔环	Ring	3	
9b	WG9003171393	塑料紧固带B8*200	Fastener	3	
9c	WG9100360134	隔环	Ring	3	
9d	190003179046	穿线护套	Protect pipe	150mm	
9e	190003179044	穿线护套	Protect pipe	150mm	

7.18 HW7E自卸车底盘电线/Chassis Wireness

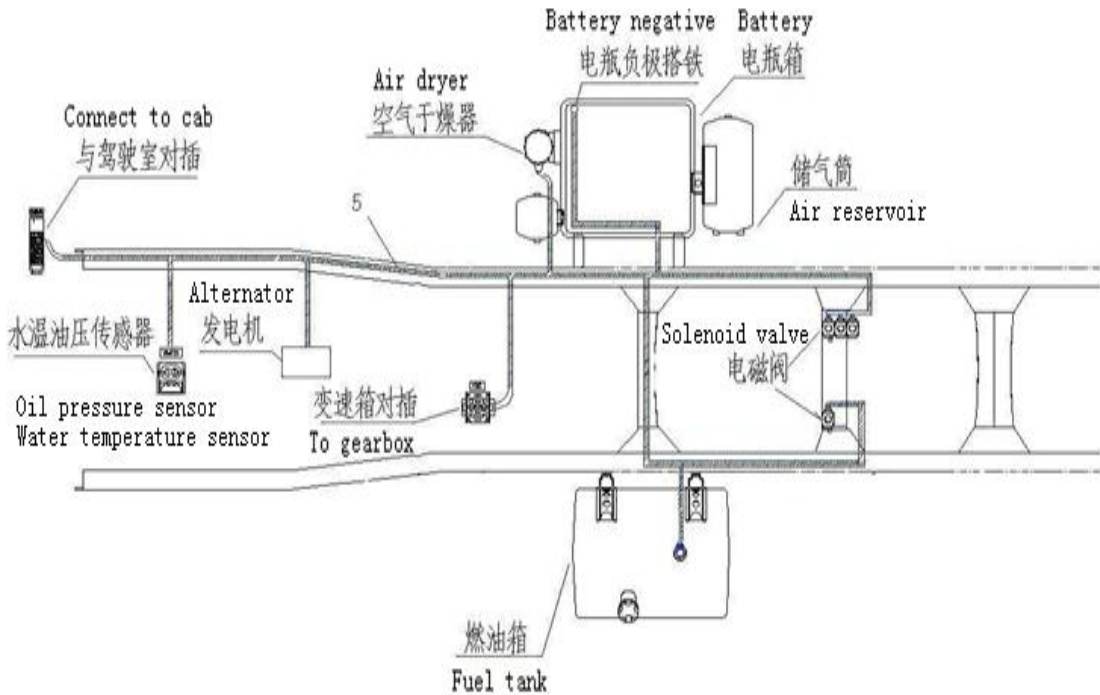

7.18 HW7E自卸车底盘电线/Chassis Wireness

序号 No.	零部件图号 Part No.	名称	Part Name	数量 Qty	备注 Remark
1	190003171697	塑料紧箍带	Fastener	10	
2	WG9003171393	塑料紧固带B8*200	Fastener	10	
4	190003179045	穿线护套	Protect pipe	150mm	
5	AZ9721770304	HW7E自卸车底盘电线束	Chassis wireness	1	

7.19 驾驶室电线束/Cab Wireness

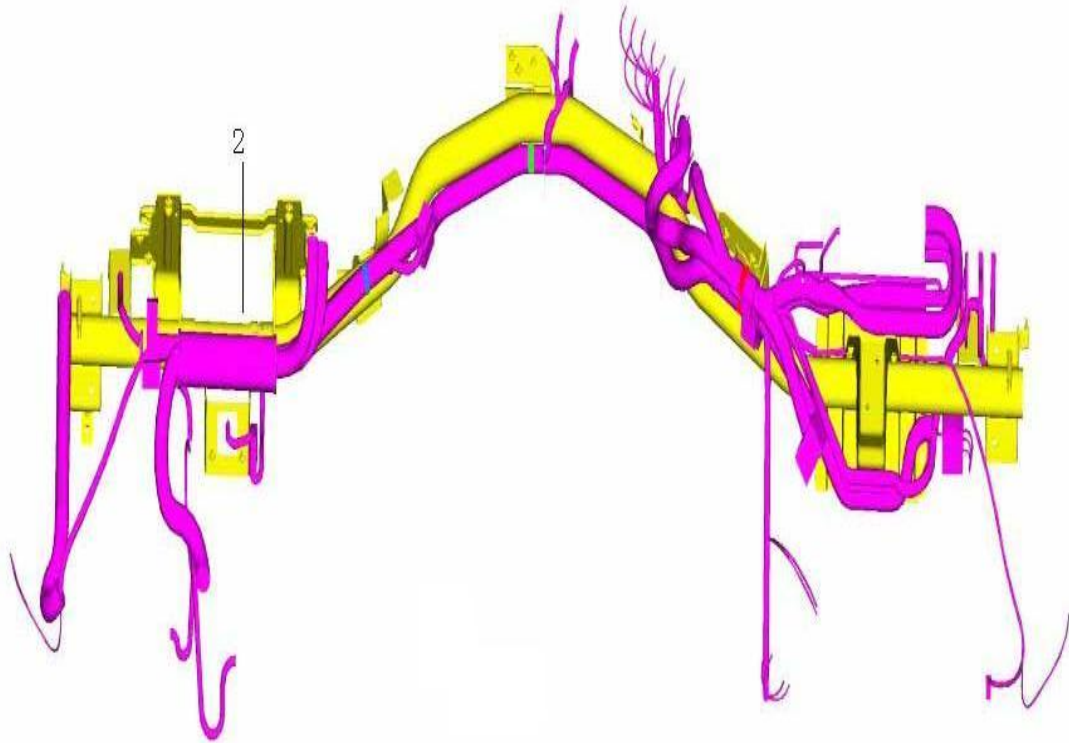

7.19 HW7E驾驶室电线束/Cab Wireness

序号	零部件图号	名称	Part Name	数量	备注
No.	Part No.			Qty	Remark
2	AZ9721770101	HW7E驾驶室电线束	Cab wireness	1	
3	Q41205	外锯齿锁紧垫圈	Washer	3	
4	Q68620	单管夹片	Clip	1	
5	Q150B0616	六角头螺栓	Screw	1	
6	Q40306	弹簧垫圈	Spring washer	1	
7	Q340B06	I型六角螺母	Nut	1	
8	WG1642110018	保护条	Strip	10	
9	WG9725584005	120Ω 电阻	120Ω Resistance	2	
10	WG9725584031	过线箱体	Box	1	
11	Q2140825	十字槽盘头螺钉	Screw	4	
12	Q340B08	I型六角螺母	Nut	4	
13	Q40108	平垫圈	Washer	8	
14	Q40308	弹簧垫圈	Spring washer	4	
15	WG9725584032	过线盒盖	cover	1	
16	Q2140420	十字槽盘头螺钉	Screw	4	
17	AZ9719770047	橡胶过孔护圈 (Φ50)	Protect ring	1	

18	WG9100770392	分线箱体	Distributing box	1	
19	179100770391	配电箱	Distributing box	1	
20	179100770387-1	连接片(11线)	Connect piece	1	
21	179100770388-1	连接片(5线) 见0387	Connect piece	2	

7.19 HW7E驾驶室电线束/Cab Wireness

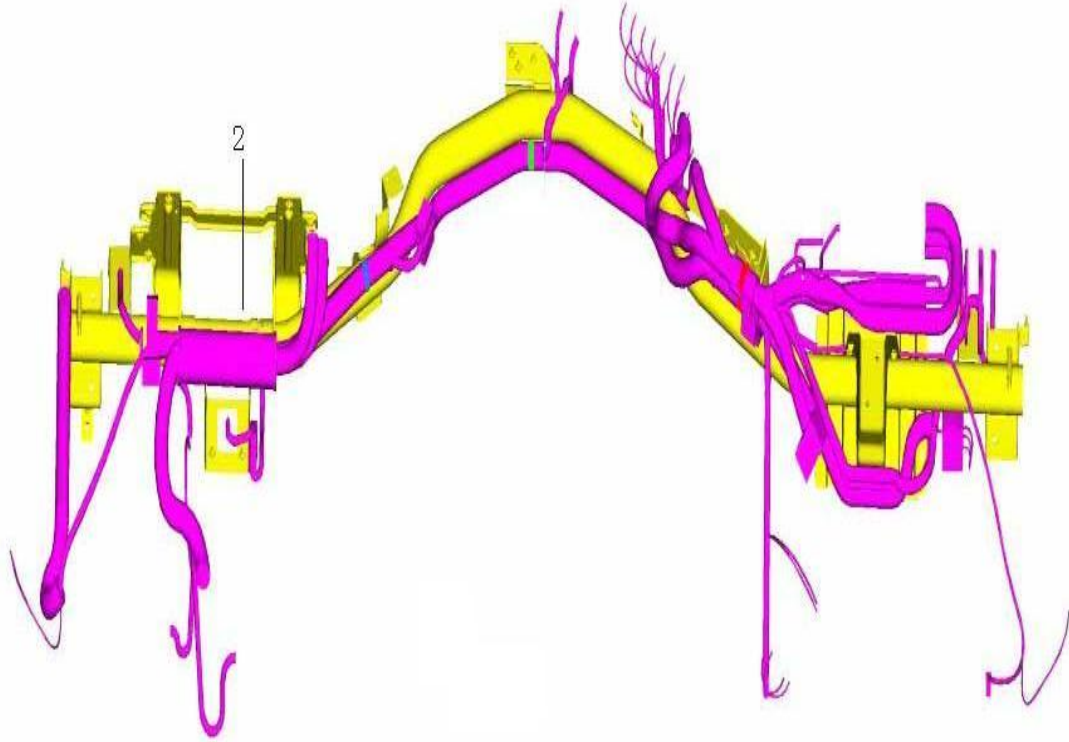

7.19 HW7E驾驶室电线束/Cab Wireness

序号	零部件图号	名称	Part Name	数量	备注
No.	Part No.			Qty	Remark
22	179100770389-1	连接片(3线) 见0387	Connect piece	4	
23	179100770414-1	连接片(4线) 见0387	Connect piece	2	
24	179100770415-1	连接片(6线) 见0387	Connect piece	1	
25	179100770416-1	连接片(8线) 见0387	Connect piece	1	
26	Q2762995	开槽半沉头自攻螺钉	Screw	3	
27	WG9100770394	分线盒盖	Distributing box cover	1	
28	179100770395	电线护套	Protect sleeve	4	
29	190003120032	园形密封条	Sealing	570mm	
30	Q2713525	十字槽盘头自攻螺钉	Screw	4	
31	Q150B0630Q	六角头螺栓	Screw	2	
32	Q40306	弹簧垫圈	Spring washer	2	
33	Q340B06	I型六角螺母	Nut	2	
34	190003171356	塑料紧固带	Fastener	15	
35	190003171392	塑料紧固带	Fastener	15	
36	WG9725584025	2.7k Ω 电阻	2.7kΩ Resistance	2	
